

三相誘導電動機 THREE-PHASE INDUCTION MOTOR

出力 OUTPUT (kW)	形 TYPE	式 FORM	定格 RATING	電圧 VOLTAGE (V)	周波数 FREQ. (Hz)	同期回転速度 SYNC. SPEED (min ⁻¹)	極数 POLES	耐熱クラス TH. CLASS	質量 MASS (kg)

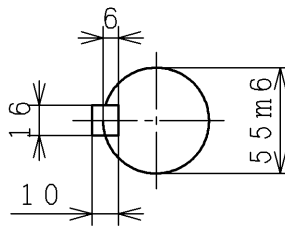
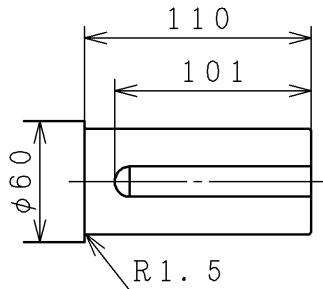
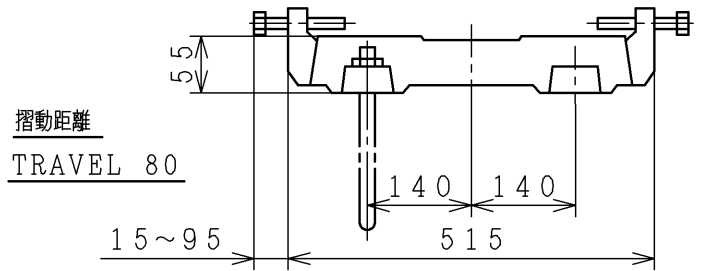
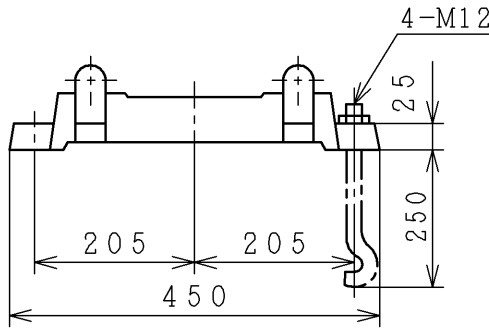
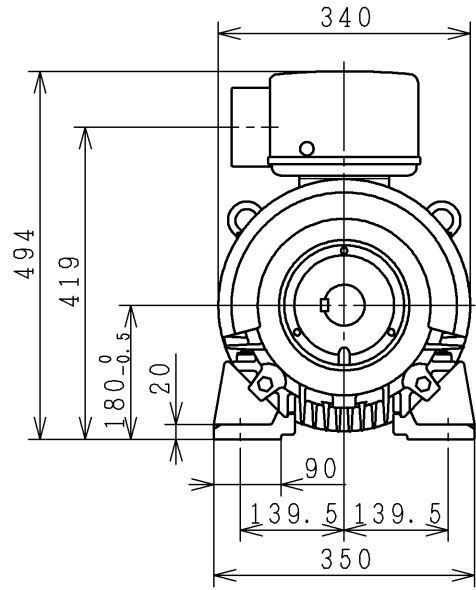
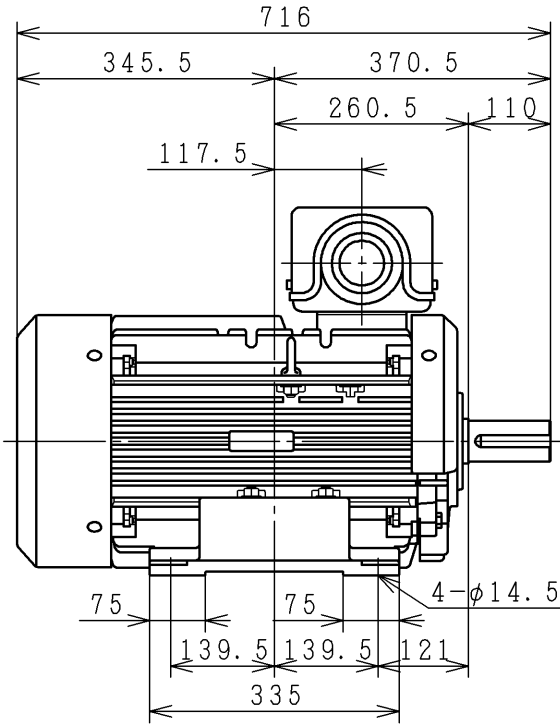

ベース BASE	付 WITH 不付 WITHOUT	キソボルト FOUNDATION BOLTS	付 WITH 不付 WITHOUT
-------------	----------------------	---------------------------	----------------------

PROJECTION

用途 USE _____ 付属品 ACCESSORY _____

備考 NOTICE

御注文主 CUSTOMER _____ 殿	数量 QTY. _____	受注番号 ORDER No. _____	作業番号 WORK No. _____	REV. 3
-----------------------	---------------	----------------------	---------------------	-----------

DWN. N. KODANI CHKD. T. KOMURA APPD. M. SENOH	Sep-11-1995 Sep-11-1995 Sep-11-1995	寸法図 DIMENSIONS	Hitachi Industrial Equipment Systems Co., Ltd.	NARASHINO WORKS DWG. No. 3244R831130	SH.
---	---	-------------------	--	---	-----

枠番 FRAME SIZE TFOAD-180L

