

三相誘導電動機 THREE-PHASE INDUCTION MOTOR

出力 OUTPUT (kW)	形 TYPE	式 FORM	定格 RATING	電圧 VOLTAGE (V)	周波数 FREQ. (Hz)	同期回転速度 SYNC. SPEED (min ⁻¹)	極数 POLES	耐熱クラス TH. CLASS	質量 MASS (kg)

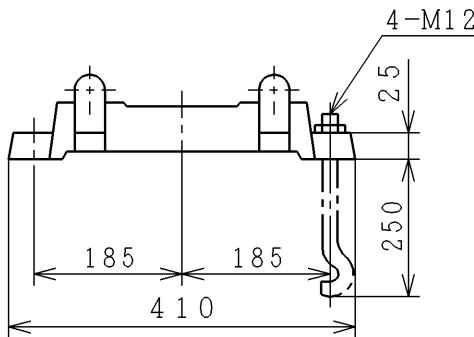

摺動距離
TRAVEL 80

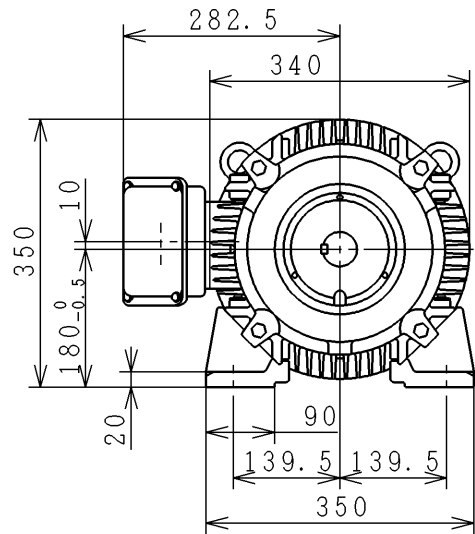
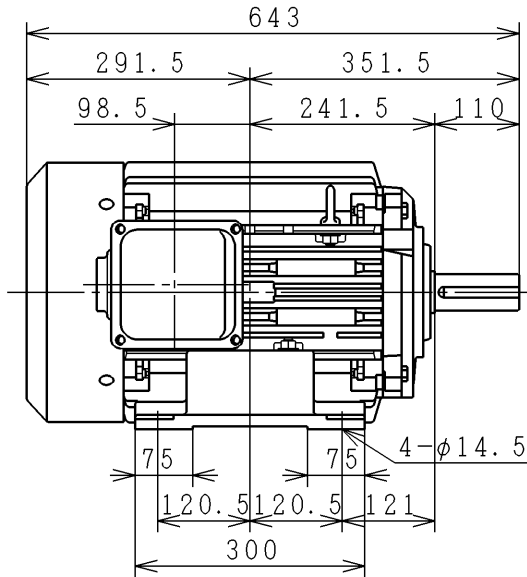
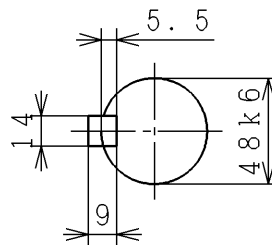
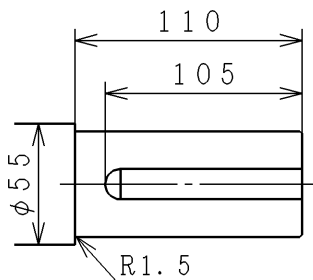
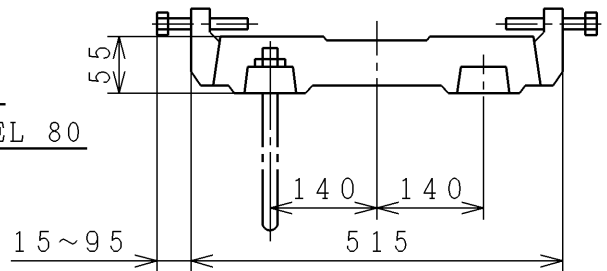

ベース BASE	付 WITH 不付 WITHOUT	キソボルト FOUNDATION BOLTS	付 WITH 不付 WITHOUT
-------------	----------------------	---------------------------	----------------------

PROJECTION	
------------	--

用途 USE _____ 付属品 ACCESSORY _____

備考 NOTICE

御注文主 CUSTOMER	数量 QTY.	受注番号 ORDER No.	作業番号 WORK No.	REV. 2
---------------	---------	----------------	---------------	-----------

DWN. N. KODANI CHKD. T. KOMURA APPD. M. SENOH	Sep-11-1995 Sep-11-1995 Sep-11-1995	寸法図 DIMENSIONS	Hitachi Industrial Equipment Systems Co., Ltd.	NARASHINO WORKS DWG. No. 3244R831129	SH.
---	---	-------------------	--	---	-----

枠番 FRAME SIZE TFOAD-180M

